

ITEM NO.	QTY.	PART NUMBER	DESCRIPTION
39	5	SSBC98024	# 10-32 X 3/8 BUT HEAD
40	2	SSBC98032	# 10-32 X 1/2 BUT HEAD
41	6	SSZH# 10096	SCREW/SHL METAL HEX 10, 1
42	4	WMFS10	WASHER FLAT # 10
43	1	ZX3829	V-BELT 3/8 x 29

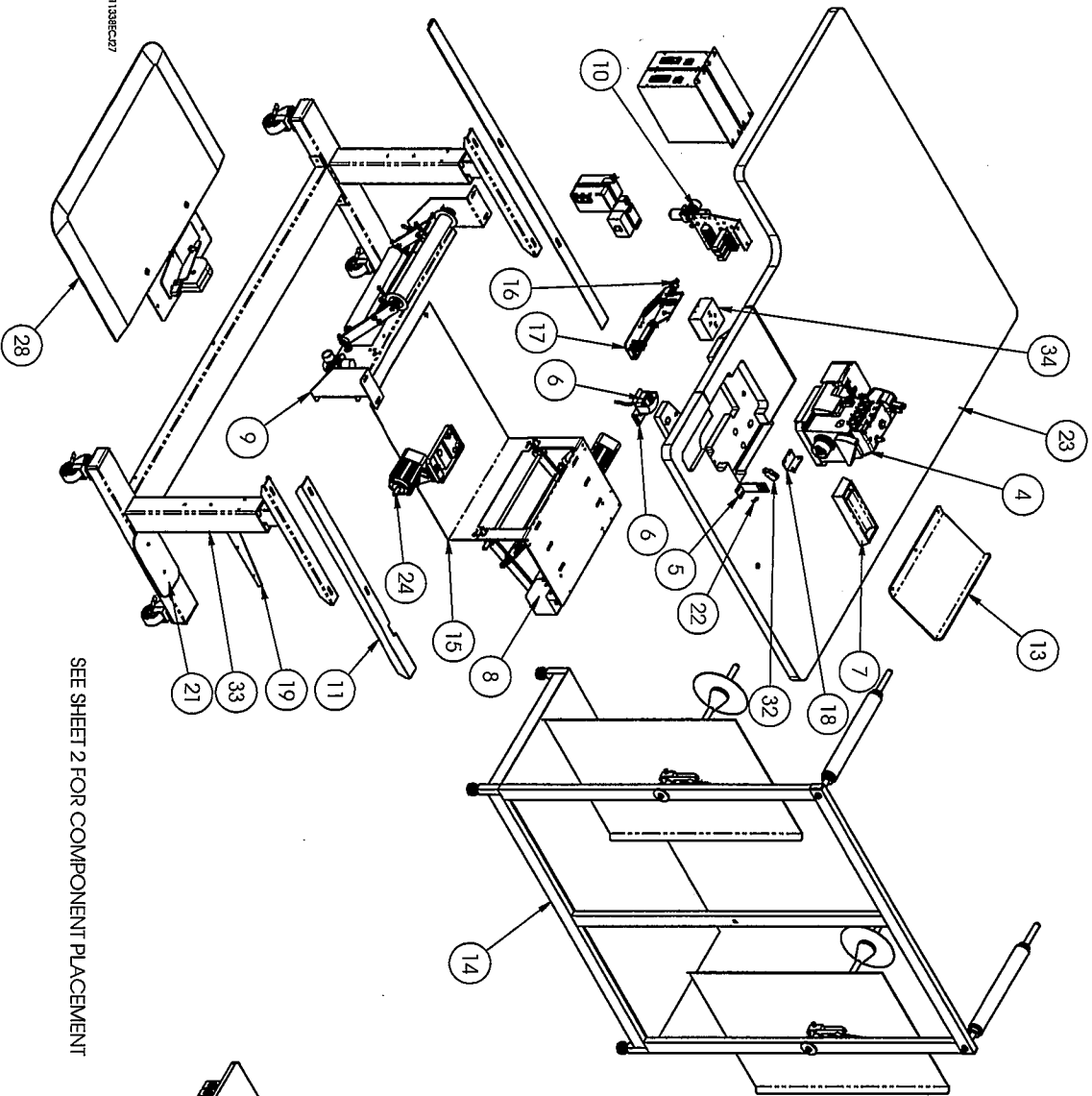

ITEM NO.	QTY.	PART NUMBER	DESCRIPTION
1	1	0211-701F	CABLE I/O EFKA
2	1	0211-702A	CABLE POS. SENSOR 6'
3	1	0211-705C	CABLE/TREADLE 6FT
4	1	11338HSJ27	SEWING HEAD SAFETY SWITCH
5	1	1278-6689D	BRACKET EYE MOUNT
6	1	1278-6718A	BRKT OPTO TOUCH SWITCH
7	1	26151	TRAY SMALL TOOL 3X9
8	1	1338003	PULLER ASSY
9	1	1338007	TENSION ASSY
10	1	1338008	PNEUMATIC PANEL ASSY 1338
11	1	1338019	SUPPORT TABLE TOP ANGLE
12	1	1338020	SUPPORT TABLE TOP ANGLE
13	1	1338022	GUARD TABLE EDGE
14	1	1338023	DUAL ROLL HOLDER ASSY
15	1	1338135	TROUGH BORDER
16	1	1338141	EDGE GUIDE ASSY
17	1	1339-100	PNEUMATIC BINDER ASSY
18	1	1380005	THREAD PLATE W/AA/F11752-3
19	1	1380016	PLATE THREAD GUIDE
20	AR	1388EC-WID	DIAGRAM WIRING
21	1	1959-112	2 POS THREAD PLATE ASSY
22	1	1975-412A	PLATE NUT 4-40@ 96 CTC
23	1	4048-3716AM2	TABLE TOP ERGO CAP
24	1	4059-DC1500	MOTOR & CONTROLLER
25	1	4059-EXT11	CABLE/TREADLE EXT.6FT
26	2	4059-EXT5	CABLE 6 COND SIGNAL
27	2	4059-EXT6	CABLE 4 COND POWER
28	1	4059-FP301B	FOOT PEDAL ASSEMBLY EFKA
29	3	AAF3/16	CLAMP BLACK PLASTIC
30	1	FHRTBVN6	SWITCH OPTO TOUCH
31	1	FHRT44T-4	CABLE EYE 12
32	1	FHSM312LVQ	BANNER MINI-BEAM
33	1	K-2001	KEY 2000-01-35-1650
34	1	K-233	BOX ELECTRICAL SQUARE
35	1	K-234	COVER 4IN SQUARE
36	1	K-CB600	MOTOR STARTER ELEC
37	4	NNK10-32	KEP NUT 10-32
38	10	SNI35X722	NEEDLE SIZE 140/22

SEE SHEET 2 FOR COMPONENT PLACEMENT

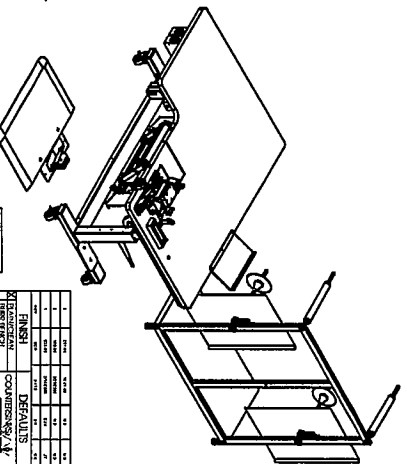

FINISH	DETAILS
1	1
2	2
3	3
4	4
5	5
6	6
7	7
8	8
9	9
10	10
11	11
12	12
13	13
14	14
15	15
16	16
17	17
18	18
19	19
20	20
21	21
22	22
23	23
24	24
25	25
26	26
27	27
28	28

ATLANTA ATTACHMENT COMPANY
 REGO CARPENTRY WORKSHOP
 1178/2005 1178/2005 1178/2005
 9000435
 3

The materials contained herein are confidential and proprietary information of Atlanta Attachment Company. In addition to any confidentiality and non-disclosure obligations that currently exist between you and Atlanta Attachment Company, your use of these materials serves as an acknowledgment of the confidential and proprietary nature of these materials.

ITEM NO.	QTY	PART NUMBER	DESCRIPTION
1	1	1338025	FRAME/ROLL HOLDER
2	2	1961-204	ROLLER,1.55L,2.0D,.75 ID
3	2	1961-253A	HUB, UNWIND STAND
4	2	1961-254B	COVER, DUAL EYE
5	2	1961-255	BRACKET, SENSOR MFG
6	4	32005004	ROD,SS,3/4 X 24,DL
7	4	33008226	DISC,10G,ASS,2.25 X 10MM
8	2	33008708	BALL BEARING, DISC ASSY
9	2	784B-2432	FLANGE, 24X24 SQUARE
10	4	CCCL12F	CLAMP COLLAR, 3/4
11	2	FFRK44T-4	CABLE EYE,12,NO END
12	2	FTT8FH100Q	EYE/HEX FELD, 4IN
13	2	MM132-1496	PLUG, 1 X 2
14	4	MMFB4444	FOOT, RUBBER
15	4	NNH1/2-13	1/2-13 HEX NUT
16	10	SSFC80016	#6-32 X 1/4 FLAT ALLEN
17	4	SSHC01064	1/4-20 X 1 HEX HEAD
18	4	SSHC25144	3/8-16 X 2-1/4 HEX HEAD
19	4	SSSC80024	#6-32 X 3/8 SOC CAP
20	2	WWMFS3/8	WASHER, FLAT, 3/8
21	4	WML3/8	3/8 LW

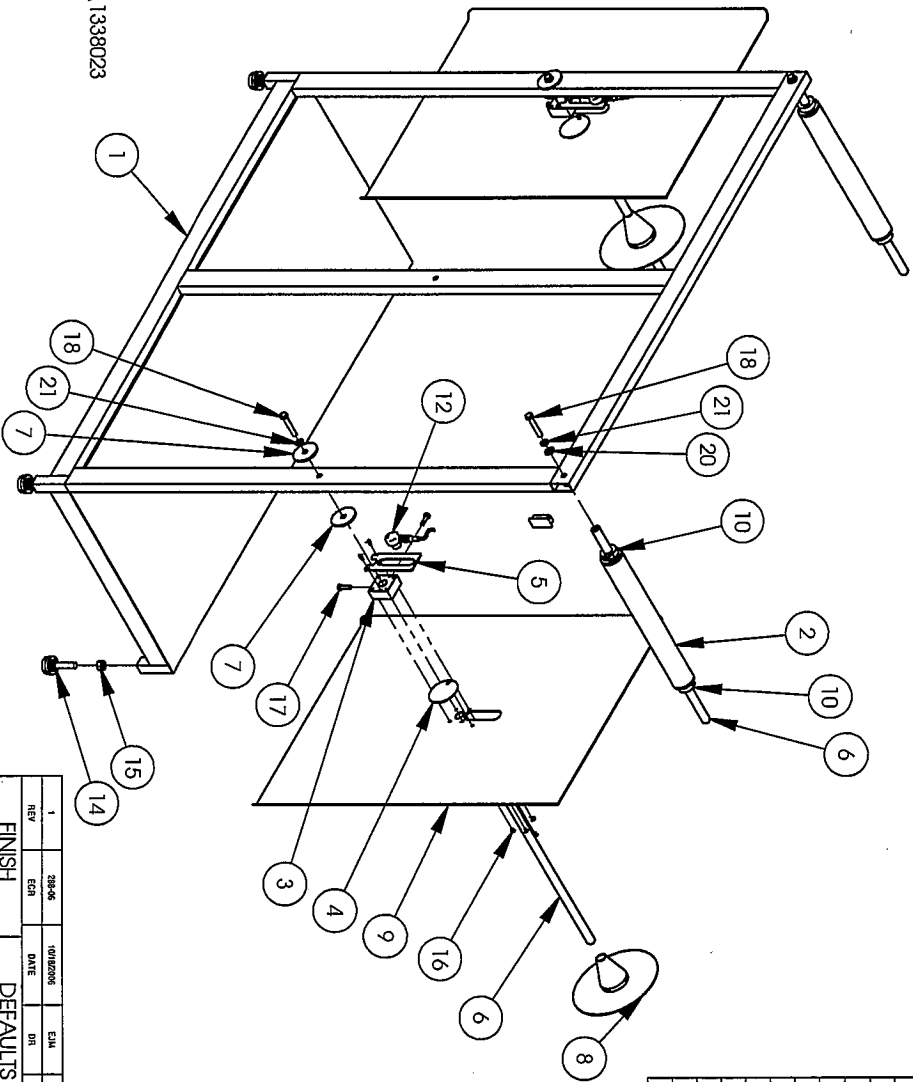

S:\13381\1338023

REV	DATE	BY	CHK
1	28-06	10/8/2006	EJM
			DR
			CK

FINISH

PLAIN/CLEAN

BLUE BENCH

BLACK/oxide

HEAT TREAT

SAND BLAST

BUFF

CLEAR CHROMIUM

PAINT

TIMESAVE

OIL

Other

DEFAULTS

COUNTERSINKS

.02

.01

.005

.002

.001

.0005

.0002

.0001

.00005

.00002

ATLANTA ATTACHMENT COMPANY

NAME: DUAL ROLL HOLDER ASSY

2ND DES:

MATERIAL: NOTED

ASSEMBLY: 11338ECJ27

DES. BY: Mctt Doshier

DR. BY: Mctt Doshier

CK. BY: Mctt Doshier

SCALE: 1:48

DATE: 3/14/2006

DWG. SIZE: A

PART NO. 1338023

DRAWING NO. 1338023

REV 1

WEIGHT: 100.048783

108-06



The materials contained herein are confidential and proprietary information of Atlanta Attachment Company. In addition to any confidentiality and non-disclosure obligations that currently exist between you and Atlanta Attachment Company, your use of these materials serves as an acknowledgment of the confidential and proprietary nature of these materials and your duty not to make any unauthorized use or disclosure of these materials.

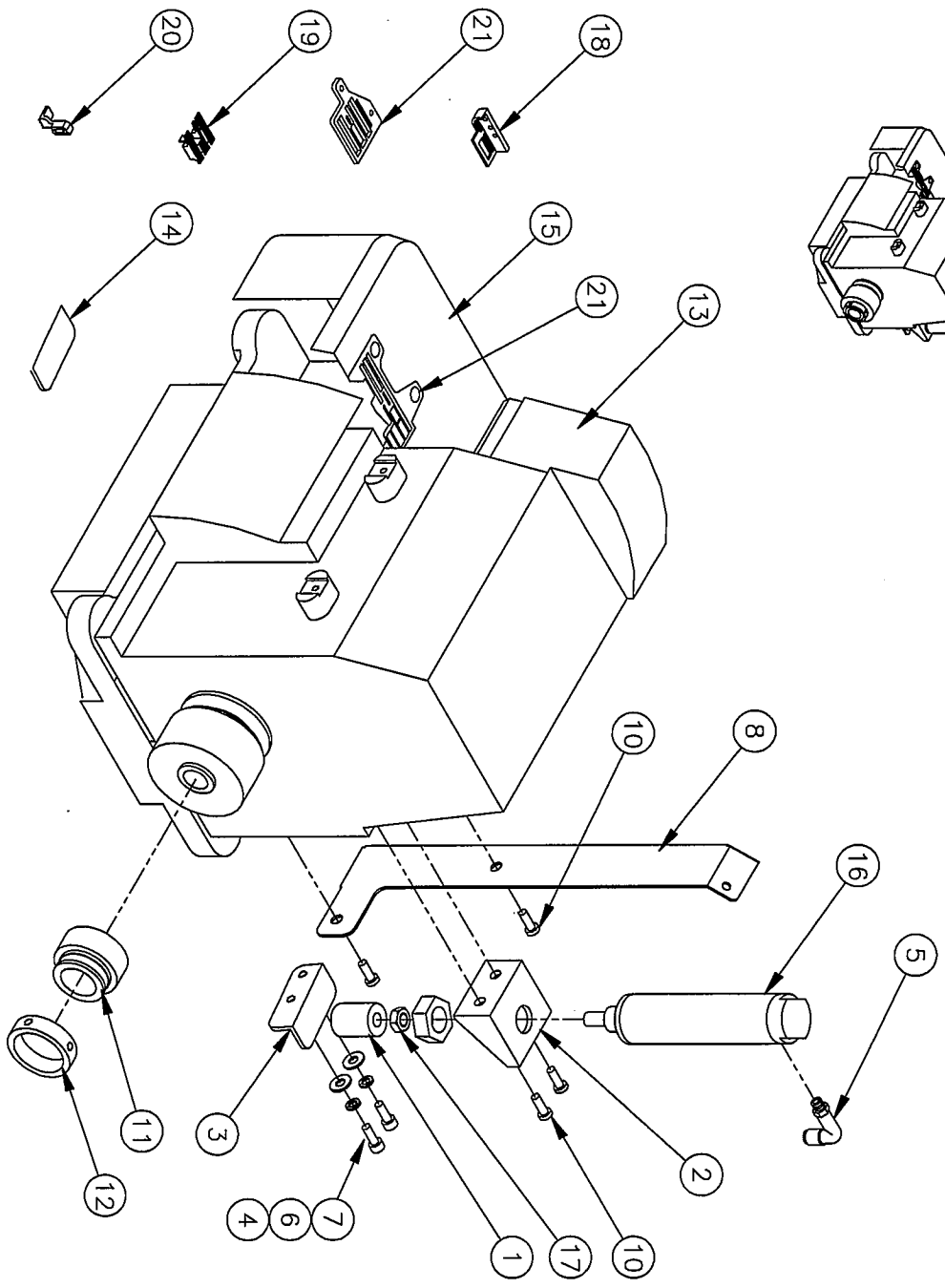
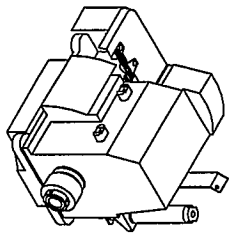

QTY.	ITEM	DESCRIPTION	PART NO.	STOCK SIZE
1	21	THROAT PLATE	M3J27-001	
1	20	FEED DOG, TOP	M2J27-002A	
1	19	FEED DOG, MAIN	M2J27-001	
1	18	PRESSER FOOT	M1J27-002A	
1	17	JAM NUT	MNU5/16-24	
1	16	AIR CYLINDER	AAC6DP-2	
1	15	CLOTH PLATE, MOD.	49021	
1	14	MNT, THROAT PLATE	49005	
1	13	SEWING HEAD	SUJK-6916A	
1	12	SLEEVE, TAPE MNT	311-129	
1	11	HUB, TAPE MNT	311-128	
4	10	SCREW, 29 x 7/16	SSM7151210	
10	9	NEEDLE	SN135X722	
1	8	THREAD GUIDE	1338-012	
1	7	SCREW, SOCKET CAP	SSSC98032	
2	6	FLAT WASHER	WWFS10	
1	5	QUICK MALE ELBOW	AAQME-5-8	
2	4	LOCK WASHER	WWL10	
1	3	ARM EXTENSION	112J27-02	
1	2	FOOTLIFT MNT BRKT	112J27-01	
1	1	BUMPER	11200A	
1	1			

NAME: SEW HEAD ASSY. TOP FEED
 OPER. M3916 JUKI

PART NO. 1133BHS127

DES. BY: WOKLEY

192979C10

DATE: 3-12-04 DWG. SIZE: C



085-04

NEW DRAWING
 AWAITING DOCUMENTATION
 SEE JERRY REVIS
 mdsdsh 3-12-2004

The materials contained herein are confidential and proprietary information of Atlanta Attachment Company. In addition to any confidentiality and non-disclosure obligations that currently exist between you and Atlanta Attachment Company, your use of these materials serves as an acknowledgment of the confidential and proprietary nature of these materials and your duty not to make any unauthorized use or disclosure of these materials.

ITEM NO.	QTY	PART NUMBER	DESCRIPTION
20	1	4059-DC1500A	MOTOR & CONTROLLER ONLY
21	4	AA198RA508	FLOW CONTROL, 5/32 X 1/8"
22	2	AA68DP-1	CYLINDER, AIR, DA
23	2	AAFBP-11C	BRKT, PIVOT, 1/4 BORE
24	2	AAFCI-11	CLEVIS, CYL, 5/16-24, 1/14
25	2	CCCL4F	COLLAR, 1/4, CLAMP
26	1	EE49111AS	PUSH BUTTON SWITCH ASSY
27	1	GG150L050	BELT, 3/8", 40T, 1/2W
28	4	NNJ1/2-20	1/2-20 HEX JAM NUT
29	2	NNJ5/16-24	5/16-24 HEX JAM NUT
30	1	PP10LF050M3	PULLEY, 3/8", 10T, 14MM BORE
31	1	PP24LB050M1	PULLEY, 3/8", 24T, 1/2 BORE
32	7	SSBC98024	# 10-32 X 3/8 BUT HEAD
33	4	SSSC70024	# 4-40 X 3/8 SOC CAP
34	3	SSSC80032	# 4-32 X 1/2 SOC CAP
35	8	SSSC98032	# 10-32 X 1/2 SOC CAP
36	4	SSSCM6X14	SCREW, SOC CAP, M6-0.8 X 14
37	4	WWF-4	WASHER, FLAT #4
38	7	WWF8	WASHER, FLAT #8
39	8	WWF810	WASHER, FLAT #10
40	3	WWF86	WASHER, FLAT #6
41	1	BBTRA815	WASHER, THRU, STEEL, 1/2

ITEM NO.	QTY	PART NUMBER	DESCRIPTION
1	1	0411-016	PLATE, NUT, MOTOR MOUNT
2	2	1325-11	ROD END, MALE, 5/16 D, X 5-2
3	1	1338004	PLATE, SUPPORT
4	1	1338005	PULLER ARM, RIGHT
5	1	1338006	PULLER ARM, LEFT
6	1	1338017	GUARD, PULLER, EXAN
7	1	1338018	GUARD, BOTTOM, PULLER
8	1	1338133	ROD, STR, 1/2X20L
9	1	33005603C	ROLLER, DRIVE, 1 1/2" CAP
10	1	33005603C2	SHFT, PREFERRED DRIVE
11	2	33005608	BLOCK, BEARING
12	1	33005609	PLATE, BEARING MOUNT
13	1	33005642	PULLER, ROLLER
14	1	33005674	BRACKET, MOTOR MFG.
15	2	33005676	?part Name
16	1	33005677	ROD, STR, 5/16, .250DX19.75L
17	1	33005681	GUARD, ENCODER
18	1	33005692	BELT, GAURD
19	1	4059-3200	PLATE, CONVERSION

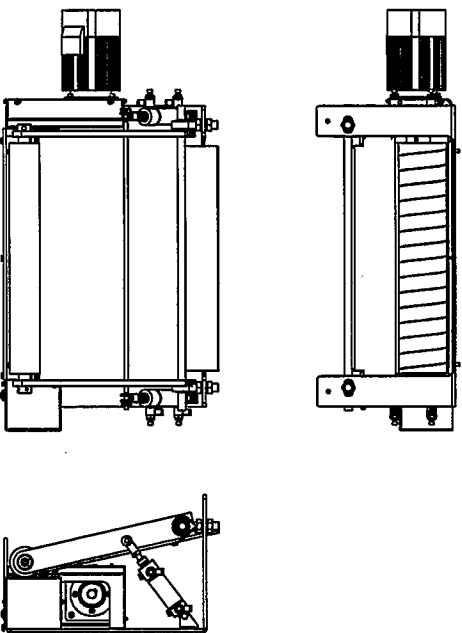
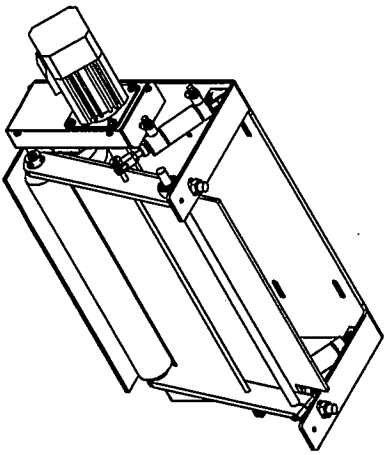

S:\1338\1338003

RESEARCH & DEVELOPMENT

WORK ORDER:	
MACHINE TIME:	QTY, FOR TRIAL
DESIGN TIME:	QTY, PER ASSY.
NEEDED BY:	
CHECKED BY:	
RETURN TO:	



346-05

FINISH	DEFAULTS
<input checked="" type="checkbox"/> PLAIN/CLEAN	COUNTERSINKS: .02
<input type="checkbox"/> BURR BENCH	
<input type="checkbox"/> BLACKOXIDE	
<input type="checkbox"/> HEAT TREAT	
<input type="checkbox"/> SAND BLAST	
<input type="checkbox"/> BLUE	
<input type="checkbox"/> PAINT	
<input type="checkbox"/> CLEAR CHROMATE	
<input type="checkbox"/> TIMERSAVE	
<input type="checkbox"/> OIL	
<input type="checkbox"/> Other	

ATLANTA ATTACHMENT COMPANY

NAME	PULLER ASSY	PART NO.	1338003
2nd DES.	11338ECJ27	DRAWING NO.	1338003
MATERIAL NOTED			
ASSEMBLY	11338ECJ27	REV	0
DES. BY	MATT DASHER	DATE	11/18/2005
DR. BY	MATT DASHER	DWG. SIZE	A WEIGHT 53.408918
CK. BY	MATT DASHER		
SCALE	1:10		

The materials contained herein are confidential and proprietary information of Atlanta Attachment Company. In addition to any confidentiality and non-disclosure obligations that currently exist between you and Atlanta Attachment Company, your use of these materials serves as an acknowledgment of the confidential and proprietary nature of these materials and your duty not to make any unauthorized use or disclosure of these materials.

ITEM NO.	QTY	PART NUMBER	DESCRIPTION
1	1	1338-024	PANEL, PNEUMATIC
2	1	AA198-5102	REGULATOR W/G ALUGE & NUT
3	3	AAEVGZ2121	VALVE, BODY PORIED
4	5	AAQME-4-8	ELBOW, QUICK MALE, 1/4X1/8
5	2	AAQPP-07	QUICK PLUG, 1/4
6	4	AAQPP-5-4	QUICK PLUG-IN REDUCER
7	9	FF264-311	TERMBLK, WAGO, TOP, SINGLE, GRV
8	5	FF264-341	TERMBLK, WAGO, TOP, DUAL, GRV
9	1	FF264-371	TERMBLK, WAGO, TOP, END
10	6	SSSC70024	#4-40 X 3/8 SOCC CAP
11	2	SSSC98082	#10-32 X 1/2 SOCC CAP
12	6	WWWF4	WASHER, FLAT #4
13	2	WWWF10	WASHER, FLAT #10
14	2	WWWL10	#10 LW

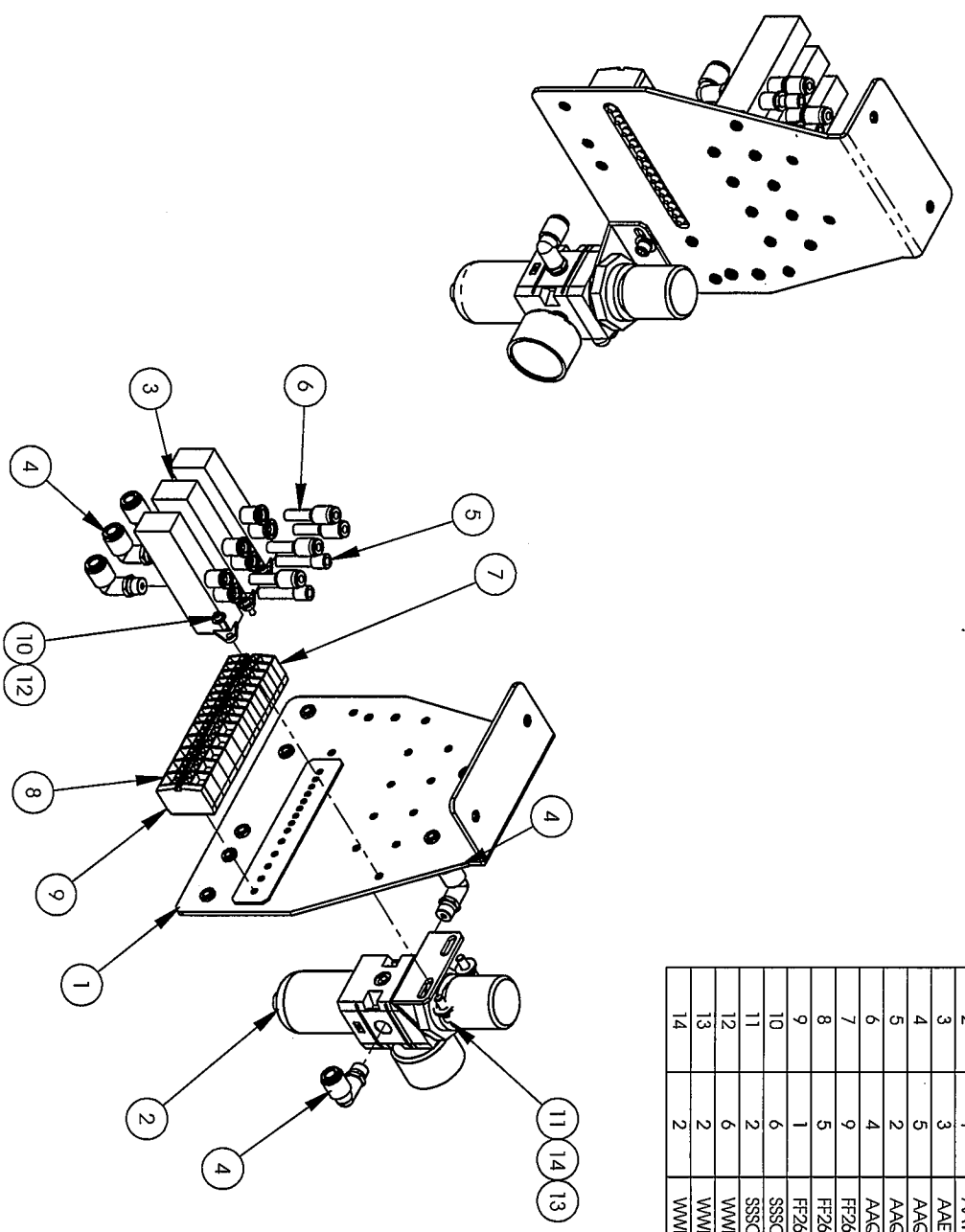

S:\1338\1338008



353-05

REV	DATE	BY	CHK
2	05-06	SHAWNS	CK

FINISH	DEFAULTS
<input checked="" type="checkbox"/> PLAIN/CLEAN	<input type="checkbox"/> COUNTERSINKS: 
<input type="checkbox"/> BURR BENCH	
<input type="checkbox"/> BLACKOXIDE	
<input type="checkbox"/> HEAT TREAT	
<input type="checkbox"/> SAND BLAST	
<input type="checkbox"/> BUFF	
<input type="checkbox"/> PAINT	
<input type="checkbox"/> CLEAR CHROMATE	
<input type="checkbox"/> TIMESAVER	
<input type="checkbox"/> OIL	

ATLANTA ATTACHMENT COMPANY	
NAME	PNEUMATIC PANEL ASSY 1338
2ND DES.	
MATERIAL NOTED	
ASSEMBLY	11338ECJ27
DES. BY	Matt Dasher
DR. BY	Matt Dasher
CHK. BY	Matt Dasher
SCALE	1:4
DATE	12/13/2005
DWG. SIZE	A
WEIGHT	2.889854
PART NO.	1338008
DRAWING NO.	1338008
REV	2

The materials contained herein are confidential and proprietary information of Atlanta Attachment Company. In addition to any confidentiality and non-disclosure obligations that currently exist between you and Atlanta Attachment Company, your use of these materials serves as an acknowledgment of the confidential and proprietary nature of these materials and your duty not to make any unauthorized use or disclosure of these materials.

ITEM NO.	Default QTY.	PART NUMBER	DESCRIPTION
1	1	1338139	GUIDE MAIN PLATE
2	1	1338140	TAB EDGE GUIDE

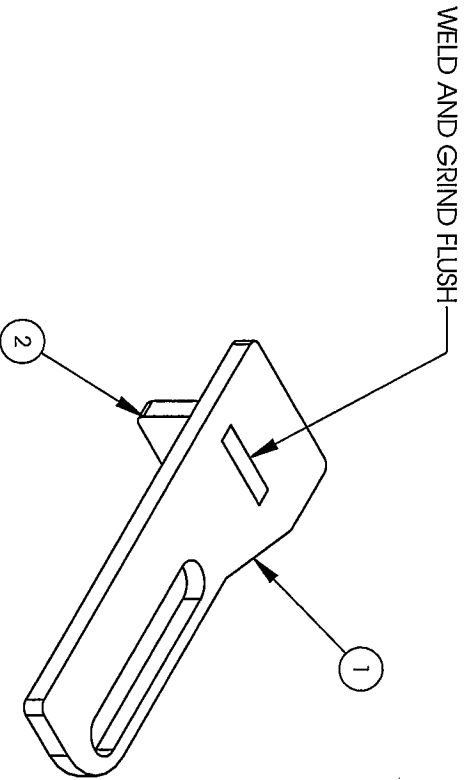

S:\1338\1338141

RESEARCH & DEVELOPMENT

WORK ORDER:	
MACHINE TIME:	QTY. FOR TRIAL 1
DESIGN TIME:	QTY. PER ASSY. 1
NEEDED BY:	
CHECKED BY:	
RETURN TO:	Matt Dasher



345-05

FINISH	DEFAULTS
<input type="checkbox"/> PLAIN/CLEAN	COUNTERSINKS: \downarrow
<input checked="" type="checkbox"/> BLUR BENCH	
<input type="checkbox"/> BLACKOXIDE	
<input type="checkbox"/> HEAT TREAT	
<input type="checkbox"/> SAND BLAST	
<input type="checkbox"/> BUFF	
<input type="checkbox"/> PAINT	
<input type="checkbox"/> CLEAR CHROMATE	
<input type="checkbox"/> TIMESAVER	
<input type="checkbox"/> OIL	
<input type="checkbox"/> Other	

Loose Tolerance

X = \pm .100
 XX = \pm .050
 XXX = \pm .015
 XXXX = AS SPECIFIED

ATLANTA ATTACHMENT COMPANY

NAME	EDGE GUIDE ASSY
2nd DES.	
MATERIAL NOTED	
ASSEMBLY	11338ECJ27
DES. BY	Matt Dasher
DR. BY	Matt Dasher
CK. BY	Matt Dasher
SCALE	1:1
DATE	11/21/2005
DWG. SIZE	A
WEIGHT	0.000000
PART NO.	1338141
DRAWING NO.	1338141
REV	0

The materials contained herein are confidential and proprietary information of Atlanta Attachment Company. In addition to any confidentiality and non-disclosure obligations that currently exist between you and Atlanta Attachment Company, your use of these materials serves as an acknowledgment of the confidential and proprietary nature of these materials and your duty not to make any unauthorized use or disclosure of these materials.

REF: USE 221-MB
STYLE BLOCK BINDERS

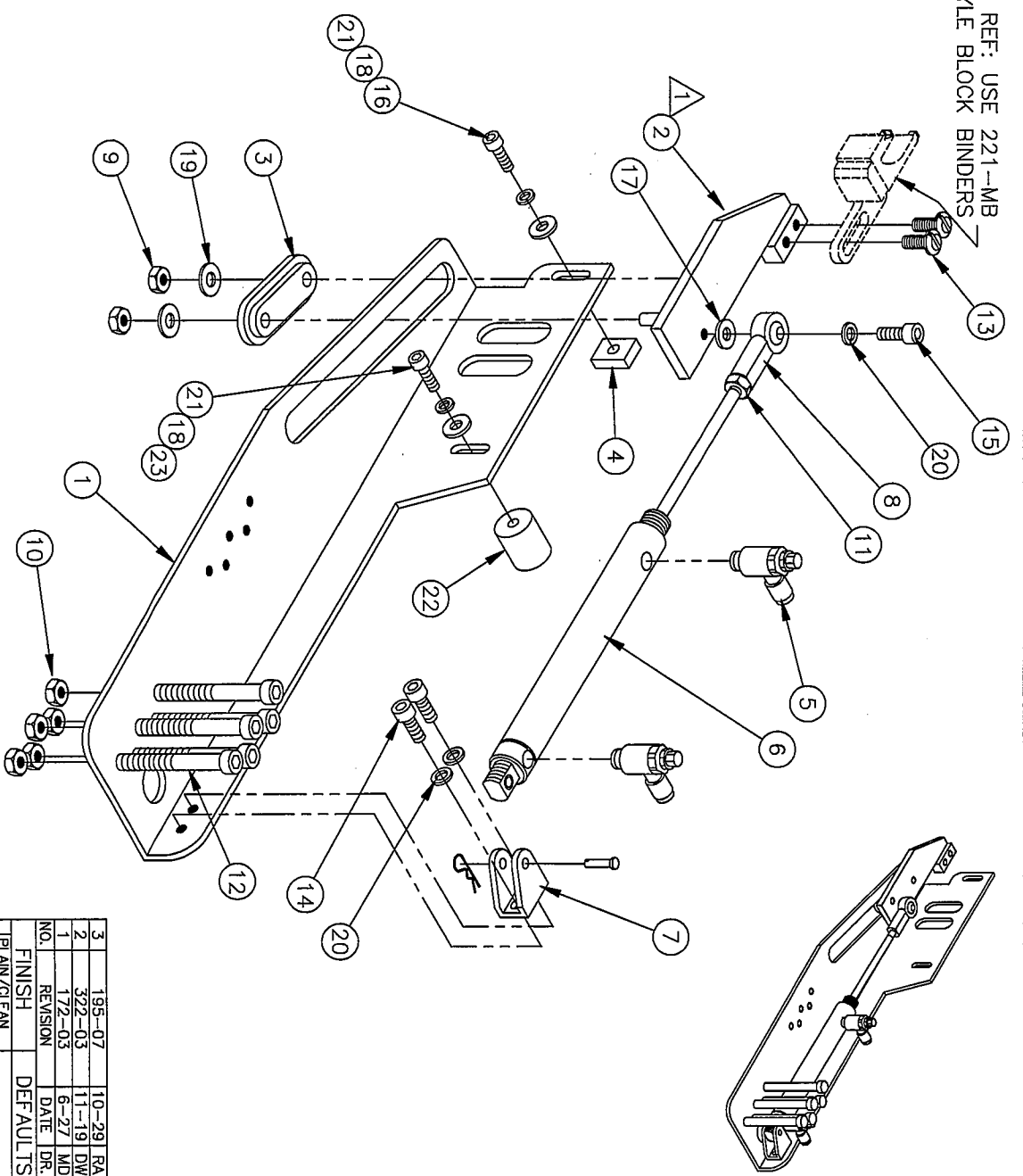

NOTE: INSURE TEFLON TAPE
ON BOTTOM SURFACE.



097-03

3	195-07	10-29	RA	JT
2	322-03	11-19	DW	JR
1	172-03	6-27	MD	JT
	REVISION	DATE	DR	CK
FINISH				
	PLAIN/CLEAN	DEFAULTS		
	BURR BENCH			
	BLACKOXIDE			
	HEAT TREAT			
	SAND BLAST			
	BUFF			
	PAINT			
	CLEAR CHROMATE			
	TIMESAVE			
	OIL			
	WELD			

QTY	ITEM	DESCRIPTION	PART NO.
NO.	NO.		STOCK SIZE
1	23	SCREW, SOCKET CAP	SSSC90080
1	22	SPACER, BINDER MNT	1339-104A
2	21	LOCK WASHER	WWL8
3	20	LOCK WASHER	WWL10
2	19	FLAT WASHER	WWFS10
2	18	FLAT WASHER	WWF8
1	17	BRASS WASHER	WWB10S
1	16	SCREW, SOCKET CAP	SSSC90048
1	15	SCREW, SOCKET CAP	SSSC98040
2	14	SCREW, SOCKET CAP	SSSC98024
2	13	SCREW, PAN HEAD SLOTTED	SSPS98032
5	12	SCREW ALLEN SHOULDER	SSAS016128
1	11	HEX NUT	NNH10-32
5	10	HEX NUT	NNH10-24
2	9	ELASTIC LOCK NUT	NNE10-32
1	8	ROD END	BBAW-3Z
1	7	PIVOT BRKT	AAFBP-8C
1	6	AIR CYLINDER	AAC8DP-3
2	5	FLOW CONTROL	AA198RA510
1	4	SPACER BLOCK	1339-104
1	3	BLOCK, SIDE	1339-103
1	2	PLATE, BINDER MNT	1339-102
1	1	MNT, MAIN	1339-101

ATLANTA ATTACHMENT COMPANY

NAME: PNEUMATIC BINDER ASSEMBLY
 2ND DES. FOR 11339
 MATERIAL NOTED
 NEXT ASSY 11339SFJ27
 DES. BY W.OXLEY
 DR. BY MAIT DASHER
 CK. BY
 SCALE 1/1.75 DATE: 3-28-03 DWG SIZE B
 PART NO. 1339-100
 DRAWING NO. 192046B
 REV 3

The material contained herein are confidential and proprietary information of Atlanta Attachment Company. In addition to any confidentiality and non-disclosure obligations that currently exist between you and Atlanta Attachment Company, your use of these materials serves as an acknowledgment of the confidential and proprietary nature of these materials and your duty not to make any unauthorized use or disclosure of these materials.

ITEM NO.	QTY.	PART NUMBER	DESCRIPTION
1	1	4059-FP301D	FOOT PEDAL ASSY, EFKA
2	1	MM4442C0036BK	MAT/DIA DEK 24 X 36 X 5/8
3	2	SSF-C98024	# 10-32 X 3/8 FLAT ALLEN
4	2	TTW10-32	THREADED INSERT, WOOD

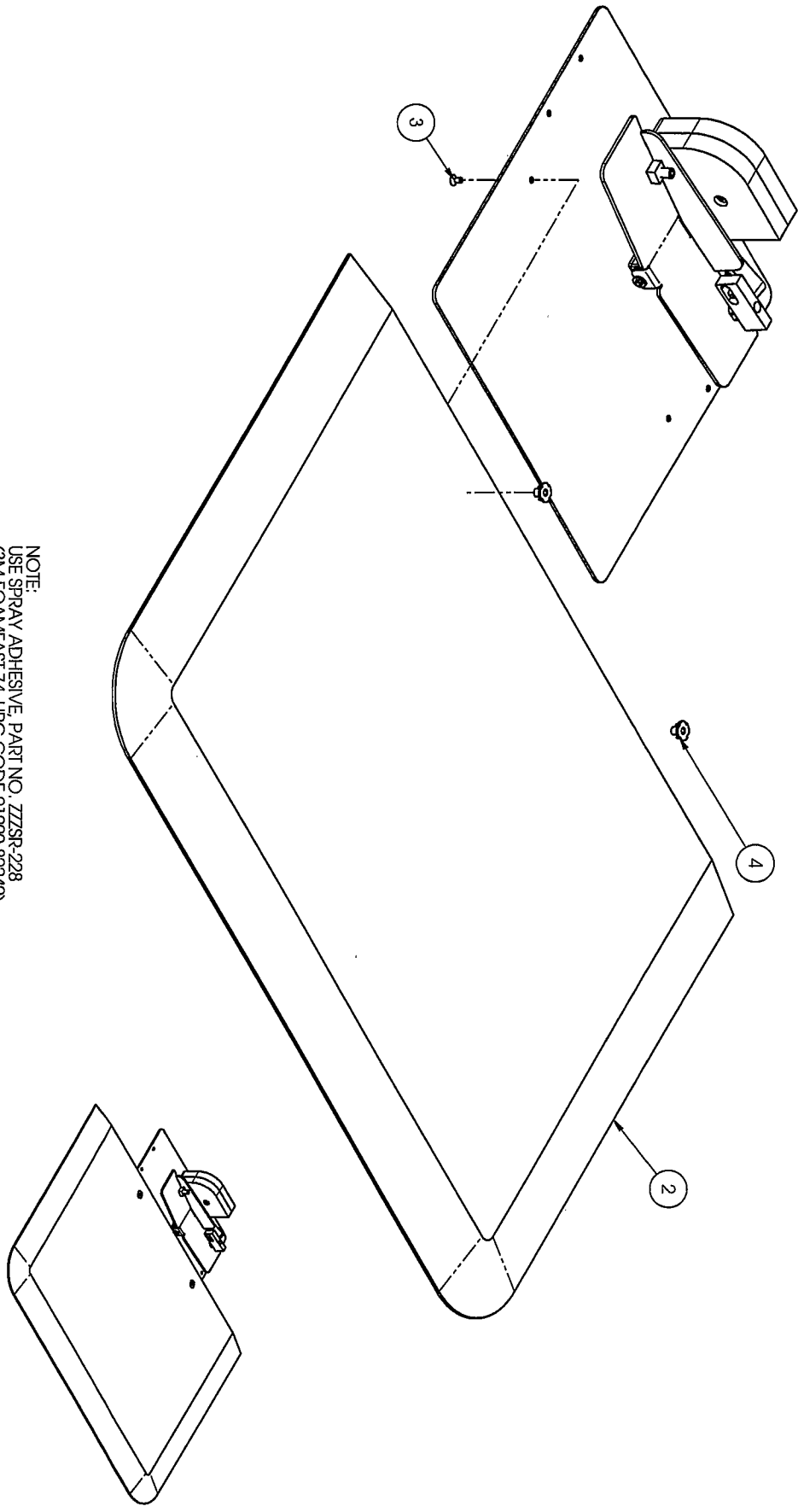

NOTE:
 USE SPRAY ADHESIVE, PART NO. ZZSR-228
 (3M FOAMFAST 74, UPC CODE 21200 82242)
 TO ATTACH DIAMOND DECK TO 4059-FP301D

The materials contained herein are confidential and proprietary information of Atlanta Attachment Company. In addition to any confidentiality and non-disclosure obligations that currently exist between you and Atlanta Attachment Company, your use of these materials serves as an acknowledgment of the confidential and proprietary nature of these materials and your duty not to make any unauthorized use or disclosure of these materials.



ITEM	DESCRIPTION	QTY	UNIT
1	FOOT PEDAL ASSY, EFKA	1	EA
2	MAT/DIA DEK 24 X 36 X 5/8	1	EA
3	# 10-32 X 3/8 FLAT ALLEN	2	EA
4	THREADED INSERT, WOOD	2	EA

ATLANTA ATTACHMENT COMPANY

NAME: WILLY WILSON
 TITLE: SALES
 PHONE: 405-9031
 FAX: 405-9031

DATE: 1/28/2003
 TIME: 1:00:00
 USER: WILSON

00000

FEEDER MOTOR PARAMETER SETTINGS		
290	5	MODE OF OPERATION (CHANSTITCH)
111	040	MAXIMUM SPEED (500 RPM)
161	0	DIRECTION OF ROTATION (CW)
270	5	POS SENSOR MODE (NONE)
* 272	125	DRIVE RATIO

* ADJUST AS NEEDED TO MATCH SEWING SPEED.
THE LARGER THE NUMBER, THE SLOWER THE FEEDER SPEED.

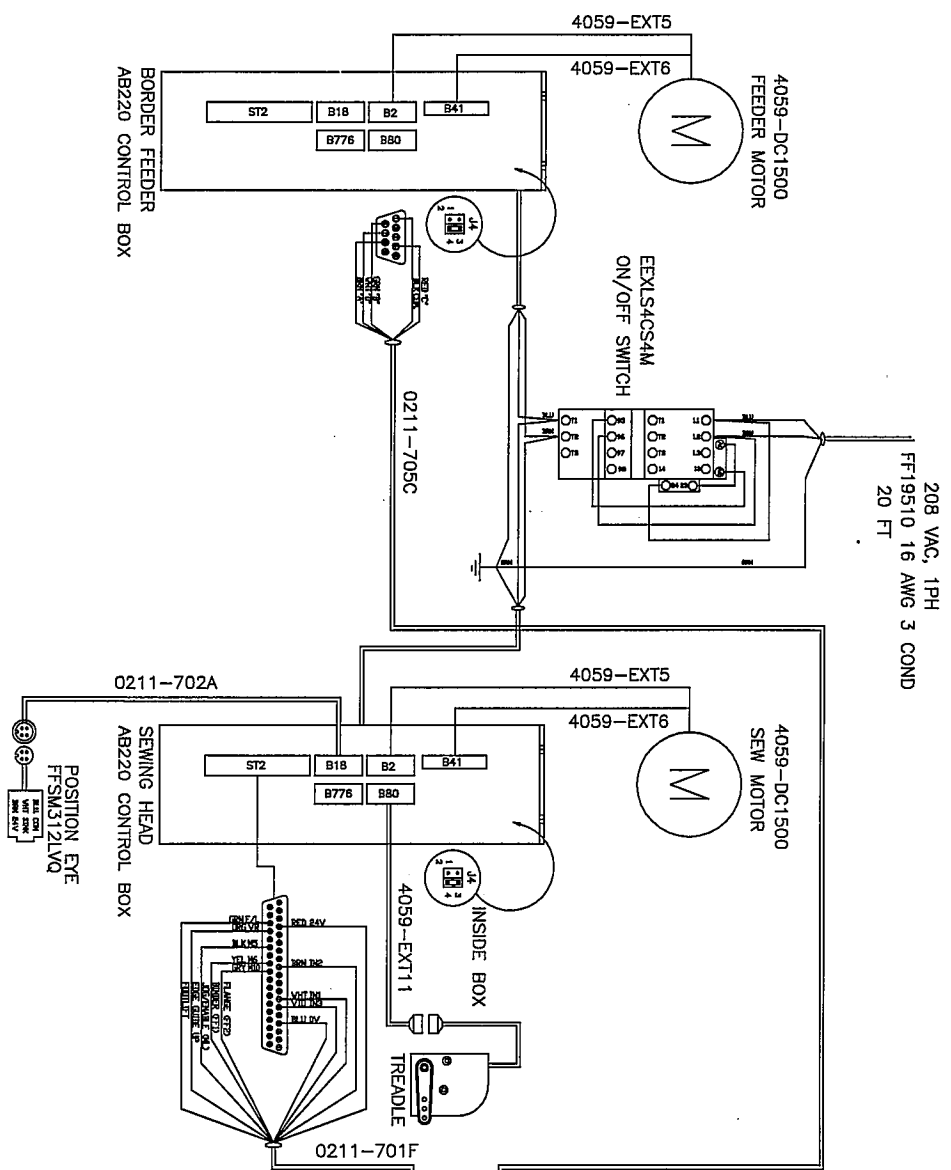

SEW MOTOR PARAMETER SETTINGS		
290	5	MODE OF OPERATION (CHANSTITCH)
111	400	MAXIMUM SPEED
117	400	HIGH LIFT WALKING SPEED LIM.
123	400	SPEED LIM. (N11)
137	1	HIGH LIFT ON/OFF
161	0	DIRECTION OF ROTATION (CW)
186	0	MODE OF FF2
204	100	FOOTLIFT (FL) HOLDING POWER
213	100	BACKTACK (VR) HOLDING POWER
240	14	HIGH LIFT OUTPUT (FLIP/FLOP 1)
241	7	MACHINE BLOCKAGE (MATL OUT)
242	22	SPEED LIM. OUTPUT (FLIP/FLOP 2)
270	1	POSITIONING SENSOR CONFIGURATION
272	100	TRANSMISSION RATIO

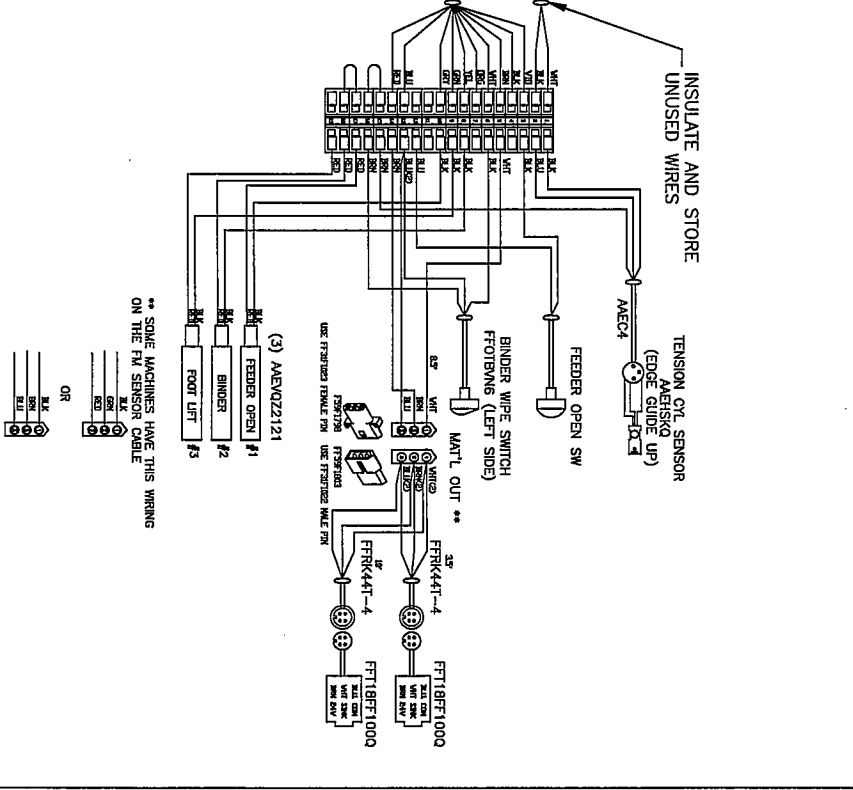

** SOME MACHINES HAVE THIS WIRING ON THE FM SENSOR CABLE

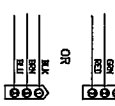

354-05

QTY.	ITEM	DESCRIPTION	PART NO.
3	183-06	E-18 TEAM	STOCK
1	185-06	S-18 MD	NO.
1	186-06	DATE DR.	SK.
FINISH			
COUNTERSINKS:			
SHEET METAL FAB			
MATERIAL			
NEXT ASSY 1133BRCJ27			
DES. BY F.DASHER			
DR. BY F.DASHER			
CHK BY MATT DASHER			
SCALE 1/6			
DATE 12-12-05			
DWG SIZE C			

ATLANTA ATTACHMENT COMPANY
PART NO. 1133BRC-ND
DRAWING NO. 125339B
REV 3

The materials contained herein are confidential and proprietary information of Atlanta Attachment Company. In addition to any confidentiality and non-disclosure obligations that currently exist between you and Atlanta Attachment Company, your use of these materials serves as an acknowledgment of the confidential and proprietary nature of these materials and your duty not to make any unauthorized use or disclosure of these materials.